

Instrucciones de montaje y utilización

Instructions for assembly and use



INSTRUCCIONES DE SEGURIDAD.-

Rogamos leer estas instrucciones atentamente, antes del montaje y del primer uso. Obtendrá importantes informaciones para su seguridad, así como para el uso y para el mantenimiento del aparato de ejercicio.

Guardar cuidadosamente las instrucciones para su información, así como para los trabajos de mantenimiento o los pedidos de piezas de repuesto.



ATENCIÓN:

Este equipo se debe utilizar solamente para su propósito previsto, es decir para el ejercicio físico de los adultos.

■ Cualquier otro uso del equipo se prohíbe y puede ser peligroso. El fabricante no se responsabiliza del daño o lesión causada por el uso incorrecto del equipo.

■ Utilice el equipo sobre una superficie sólida y nivelada.

■ El equipo deberá disponer a su alrededor de un espacio libre no inferior a 0,5 m.

■ El equipo se ha diseñado de acuerdo con lo más último en los estándares de seguridad.

■ Este equipo está conforme con el estándar EN 957. Adecuado para uso profesional, con un peso máximo del usuario 150kg.

■ Las reparaciones incorrectas y/o las modificaciones estructurales del equipo (Ejemplo: Retirar o el reemplazar piezas, no originales) pueden poner en peligro la seguridad del usuario.

■ Los componentes dañados pueden poner en peligro su seguridad y/o reducir curso de la vida del equipo.

Por esta razón, las piezas dañadas se deben sustituir inmediatamente y el equipo mantenerlo fuera de uso hasta que se haya reparado. Utilice solamente el repuesto original de piezas BH.

■ El si el equipo está en uso regular, comprobar todos sus componentes a fondo cada 1 ó 2 meses, prestando atención muy particular al reapriete de tuercas y tornillos.

■ Antes de comenzar su programa del ejercicio, consulte a su doctor para asegurarse de que puede utilizar el equipo.

Base su programa del ejercicio en el consejo dado por su doctor o preparador físico.

Los ejercicios incorrectos o excesivos pueden dañar su salud. Trabaje en el nivel de ejercicio recomendado, no llegue al agotamiento.

■ Preste por favor mucha atención a las indicaciones del manual del entrenamiento.

Para la realización del montaje de este equipo, son necesarios dos personas al menos, como le muestran las figuras adjuntas de este manual de instrucciones.



SAFETY INSTRUCTIONS

Please read these instructions carefully before assembling and using the equipment. They contain important information for your safety and for the use and maintenance of the exercise equipment.

Keep the instructions safe for future reference and maintenance tasks as well as for ordering spare parts.



ATTENTION:

- This equipment must only be used for its intended purpose, i.e. physical exercise.
- Any other use of the equipment is prohibited and may be dangerous. The manufacturer is not responsible for damage or injury caused by misuse of the equipment.
- Use the equipment on a solid level surface.
- The equipment must have at least 0.5 metres of free space around it.
- The equipment is designed in accordance with the latest safety standards.
- This equipment complies with standard EN 957. Suitable for professional use, with a maximum user weight of 150kg.
- Incorrect repairs and/or structural modifications to the equipment (E.g.: Removal of parts or non-original replacement parts) can endanger the user's safety.
- Damaged components may endanger your safety and/or reduce the useful life of the equipment.
For this reason, damaged parts must be replaced immediately and the equipment taken out of use until it is repaired. Use only original BH spare parts.
- If the equipment is in regular use, check all components thoroughly every 1 or 2 months, paying particular attention to retightening nuts and bolts.
- Before beginning your exercise program, consult your doctor to make sure that you can use your exercise equipment.
Base your exercise program on the advice given by your doctor or trainer.
Incorrect or excessive exercise can damage your health. Work at the recommended exercise level, do not overexert yourself.
- Pay close attention to the trainer's exercise instructions.

It is necessary at least, the assistance of a second person when assembling this machine, as shown in the diagrams that accompany this instruction manual.



Saque la unidad de la caja, compruebe e identifique las piezas con respecto al listado de la Fig.A y Fig.B, para asegurarse de que no falta ninguna pieza, para el montaje del equipo, en la primera fase.





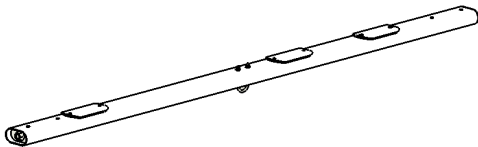
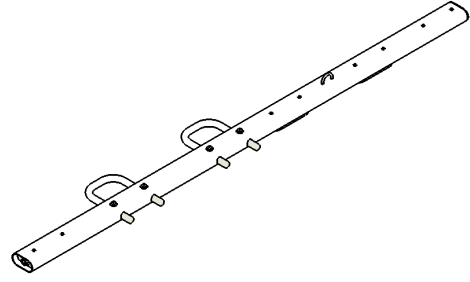
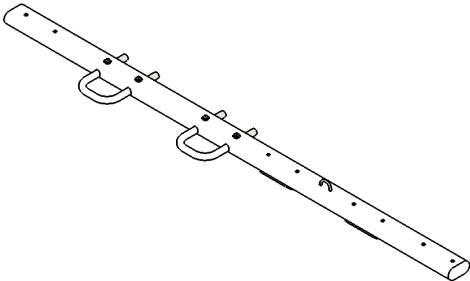
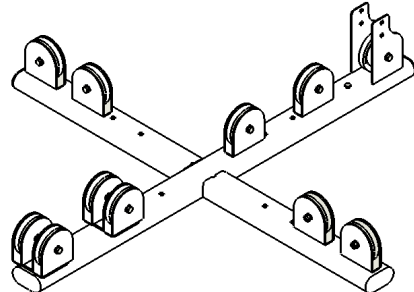
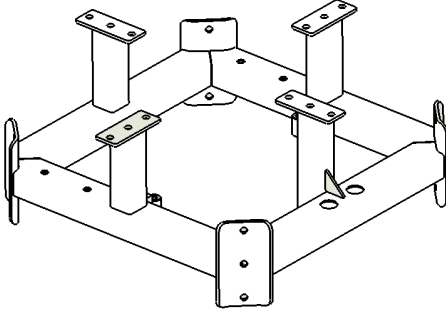
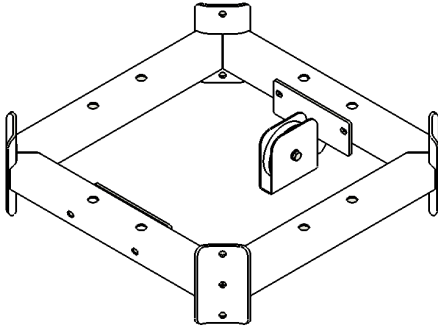
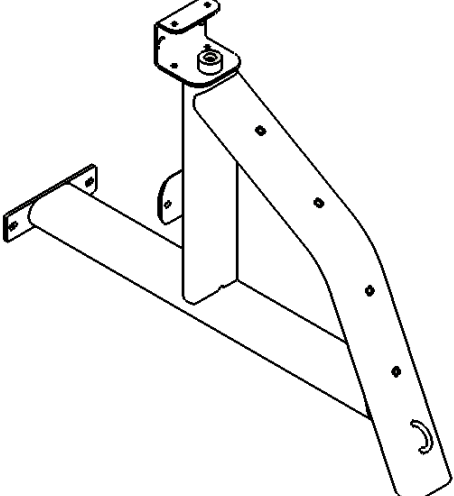
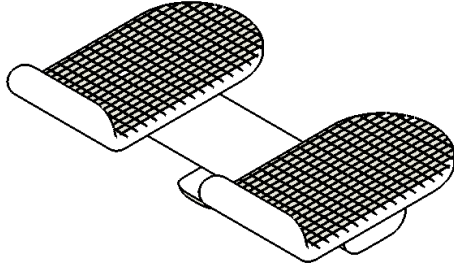

Take the unit out of its box, check and identify the parts against the list in Fig.A and Fig.B to ensure that there are no missing parts for the initial assembly stage of the equipment.

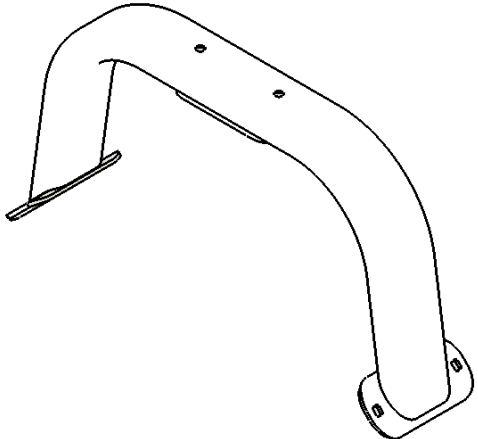
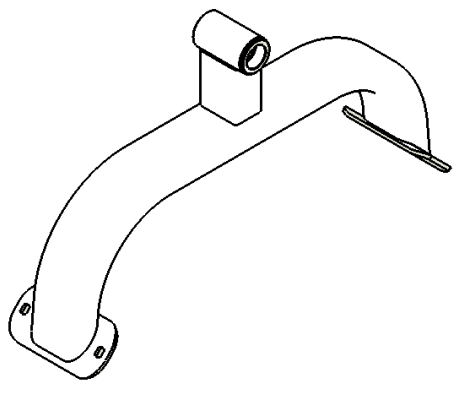
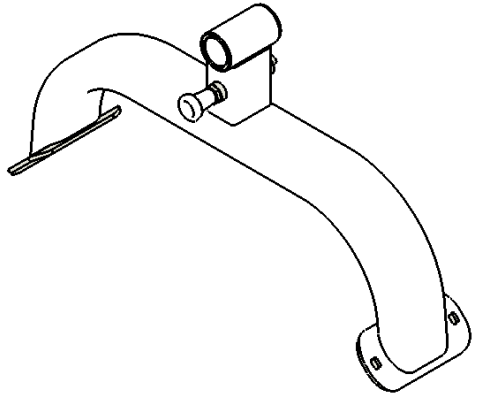
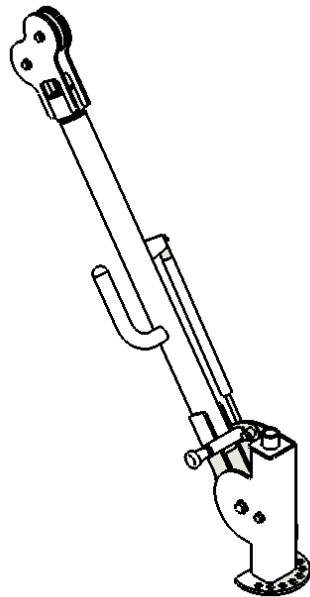
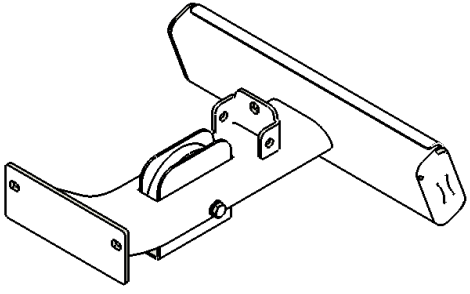
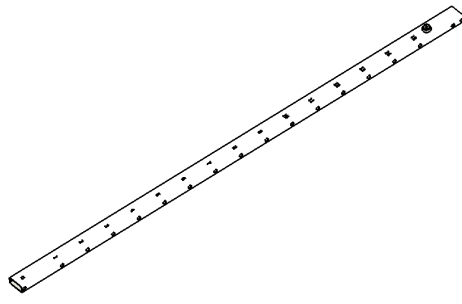
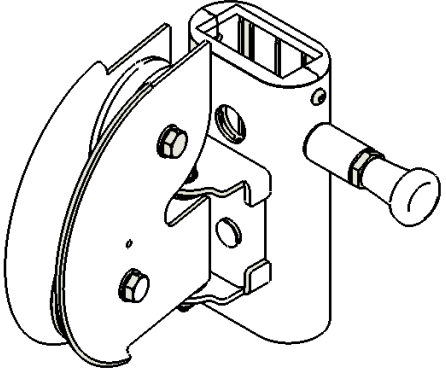
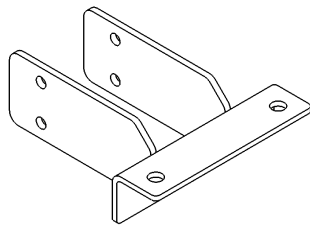
Fig.A

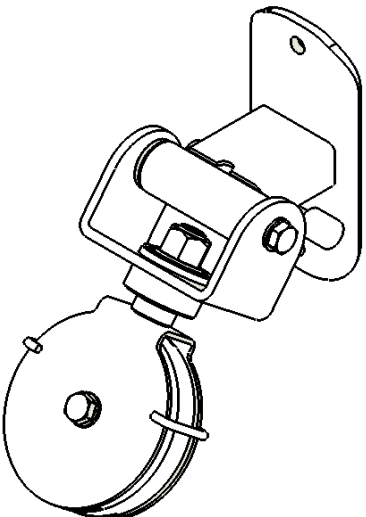
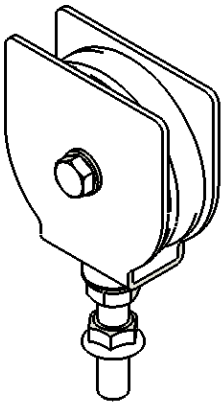
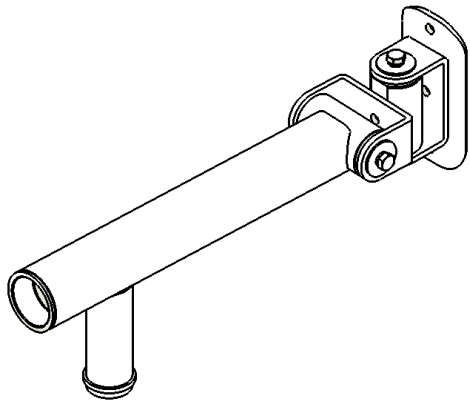
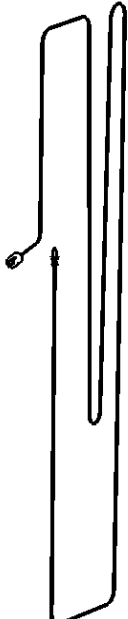
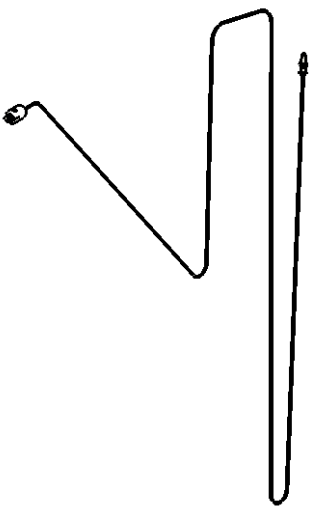
Nº		✓	Nº		✓
1		2	2R		1
2L		1	3		1
4		1	5		1
6		1	7		1

8		1		9		2
10		2		11		2
13		1		14		1
15		1		16		1

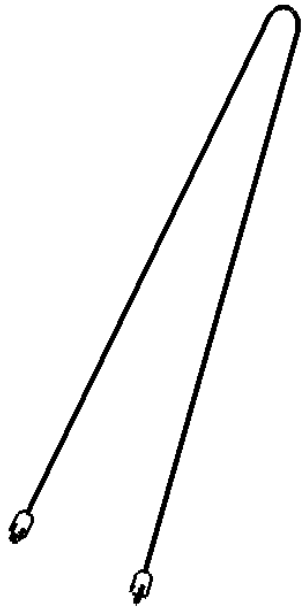
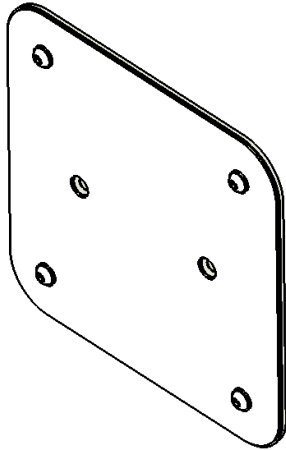
17		1		20		4
21		2		28		1
29		2		30		1

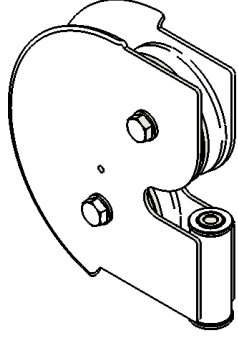
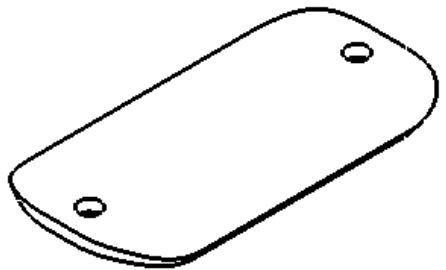
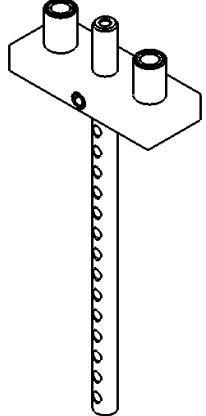
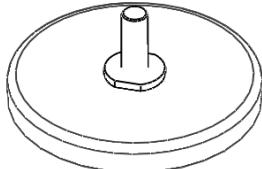
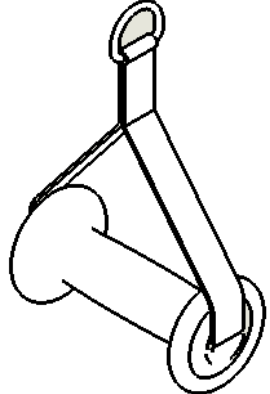
31		1		32		1
34		8		36		2
38		5		39		4
40		6		41		7











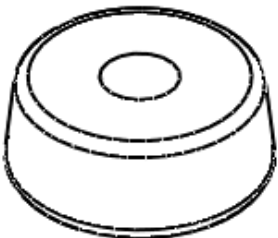
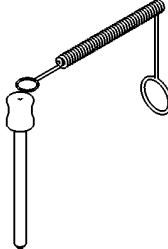
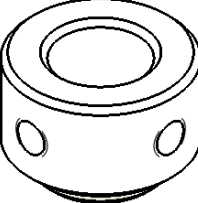
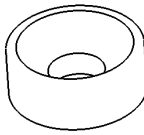









42		8		43		4
44		8		48		1
81		7				

Fig.B

Nº		✓			✓
83	 M-8x100	2		84  M-10x30	2
89	 M-10x75	8		90  M-10x80	38
92	 M-10x100	1		93  M-10x105	6
97	 M-10x25	2		99  M-12x70	1
105	 M-8x8	16		106  M-8	4
107	 M-10	108		108  M-12	1
116	 M-8	2		117  M-10	53
118	 M-12	1		126  Hex Key S=3/16"	1
127	 Hex Key S=4	1		128  Hex Key S=6	1
129	 Hex Key S=8	1			

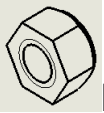

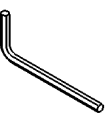
NOTA: La descripción de las piezas con respecto a las figuras, corresponden siempre a la posición de la persona en el equipo para la realización del ejercicio.

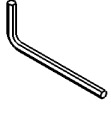

NOTE: The description of the parts with respect to the figures always corresponds to the position the person adopts on the equipment when exercising.

Fig.1

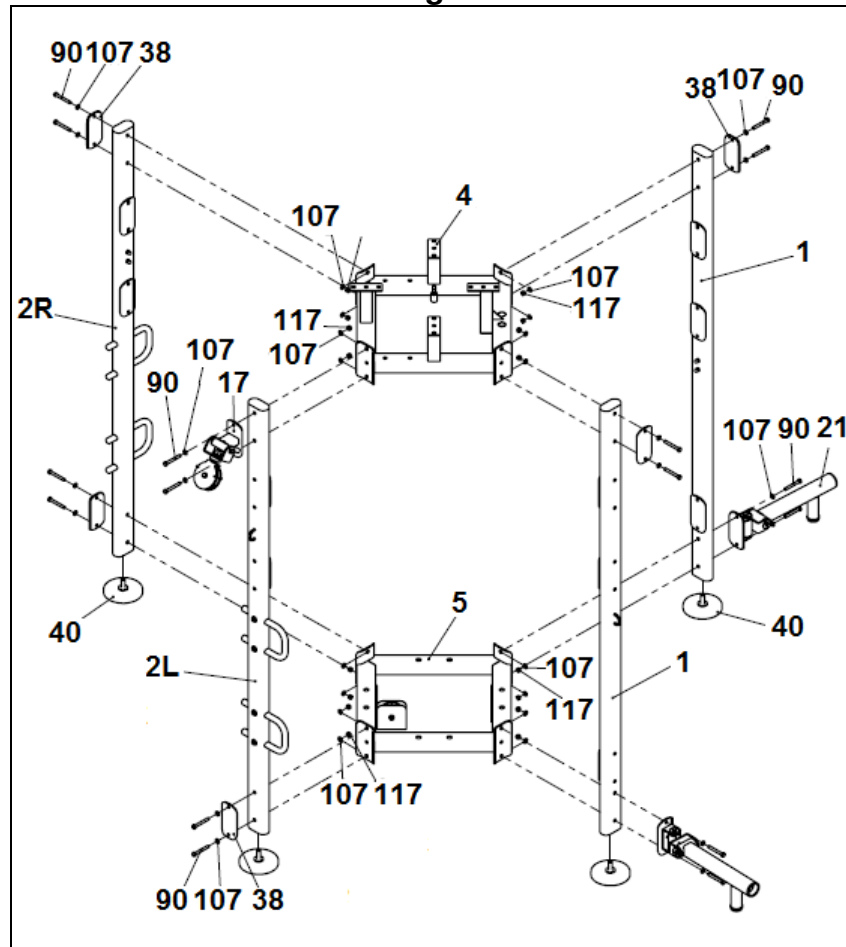

INSTRUCCIONES DE MONTAJE.-

Apoye en el suelo el soporte principal (5).

Coloque en las barras laterales (1), (2R), (2L) los tacos de apoyo (40) y atorníllelos con los tornillos junto con las arandelas y las tuercas suministrados en los tacos (40).

Coloque en las barras laterales (1), (2R), (2L) las pletinas (38), la polea superior (17) y los soportes barra (21) y atorníllelos con los tornillos (90) junto con las arandelas (107) y tuercas (117) tal como se muestra en la figura 1 al soporte inferior (5) y al soporte superior (4).



INSTRUCTIONS FOR ASSEMBLY.-

Rest on the floor the main support (5). Place in lateral bars (1), (2R), (2L) the adjusting pads (40) and tighten the screws with washers and nuts provided inside the pads (40). Place the lateral bars (1), (2R), (2L) the plates (38), the upper pulley (17) and the fixed frames (21) and tighten the screws (90) with washers (107) and nuts (117) as shown in Fig 1 to the main support (5) and upper support (4).

Fig.2

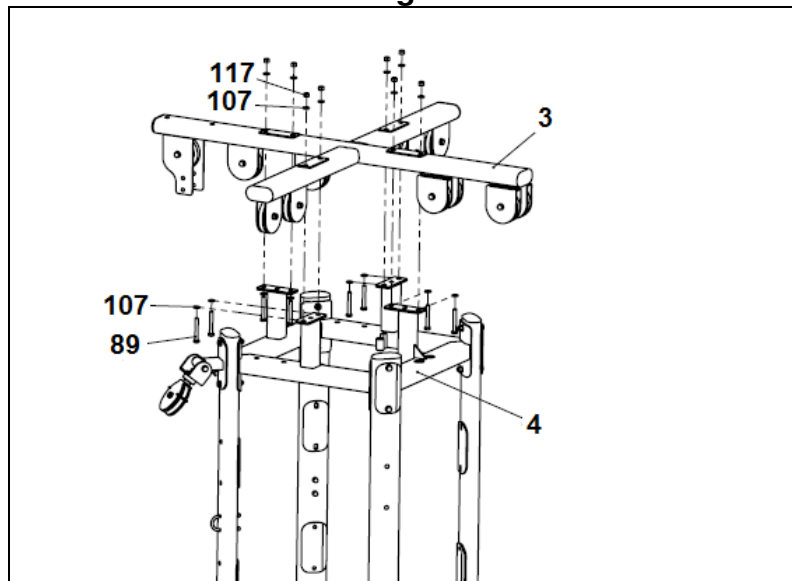

Atornille el soporte brazos (3) al soporte superior (5) atorníllelos con los tornillos (89) junto con las arandelas (107) y tuercas (117) manteniendo la posición tal como se muestra en la figura 1.



Tighten the arm support (3) to the upper support (5) with screws (89), washers (107) and nuts (117) maintaining the position as shown in Fig 1.

Fig.3

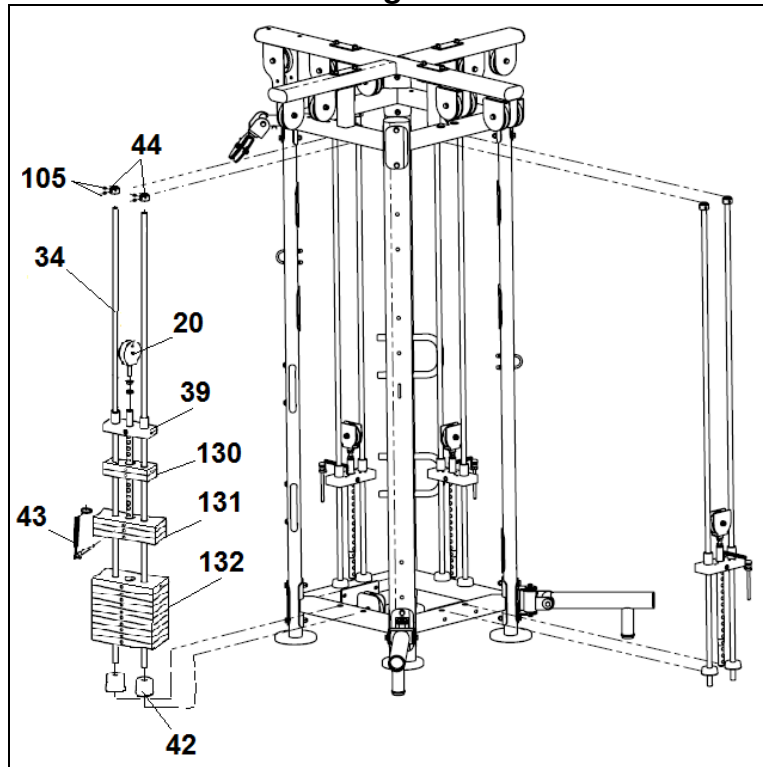

Sitúe el tope de pesas (42) en la torre de pesas, introduzca las barras de pesas (34). A continuación coloque las pesas (130); (131); (132), siempre las de mayor peso en la parte inferior, por ultimo coloque la pesa de guía con su barra selector (39), atornille las barras de pesas por la parte superior con las arandelas (44) y los tornillos (105). Coloque la anilla del selector (43), en el casquillo central de la pesa guía (39). Realice el mismo montaje para los otros tres lados.



Place the weight stop (42) on the weight stack, insert the weight guide bars (34). Then place the weights provided (130); (131); (132) the heavier weights always at the bottom. Finally fit the guide weight with the selector bar (39), tighten the top of weight guide bars using washers (44) and screws (105). Fit the selector ring (43) into the central bushing on the weight guide (39). Now go through the same procedure for the other three sides.

Fig.4

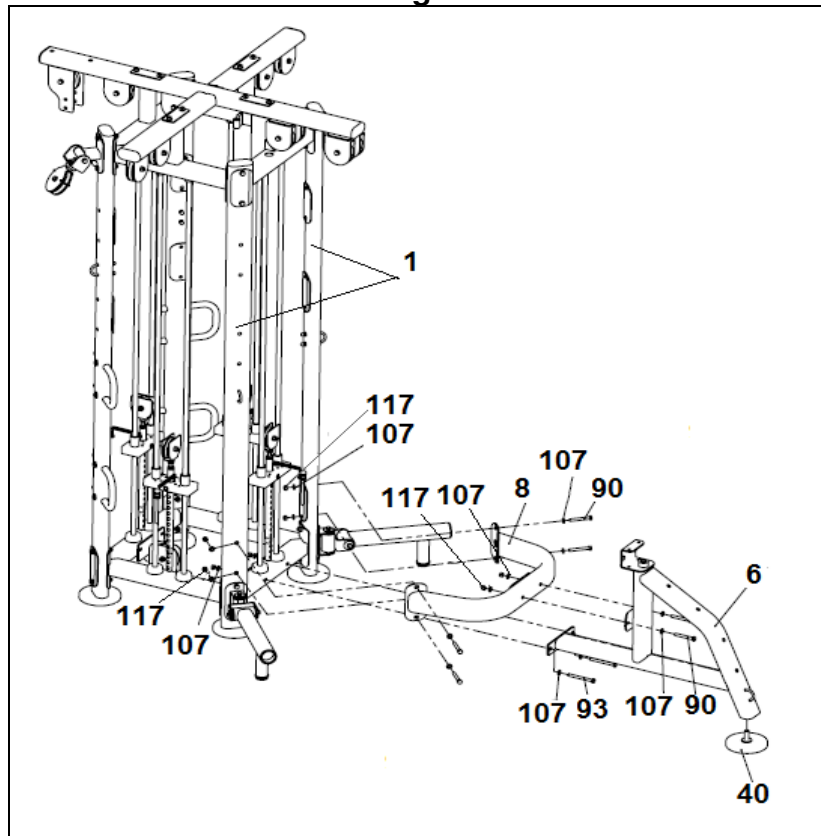

E

Coloque en el soporte del banco remo (6) el taco de apoyo (40) y atorníllelo con el tornillo junto con la arandela y la tuerca incluida en el taco (40). Coloque el soporte (8) sobre las barras (1) y atorníllelo con los tornillos (90) junto con las arandelas (107) y las tuercas (117).

Acerque el soporte del banco remo (6) hasta hacer coincidir con el soporte (8). Atornillar el soporte banco remo (6) al soporte (8) con los tornillos (90) junto con las arandelas (107) y las tuercas (117) y al soporte principal (5) con los tornillos (93) junto con las arandelas (107) y las tuercas (117).

GB

Place the adjusting pad (40) in the rower support (6) and screw with the screw, washer and nut included in the pad (40).

Place the bracket (8) on the bars (1) and tighten with the screws (90) along the washers (107) and nuts (117).

Bring the rower support (6) to join with the support (8). Tighten the rower support (6) to the support (8) with screws (90) along washers (107) and nuts (117) and the main support (5) with screws (93), washers (107) and nuts (117).

Fig.5

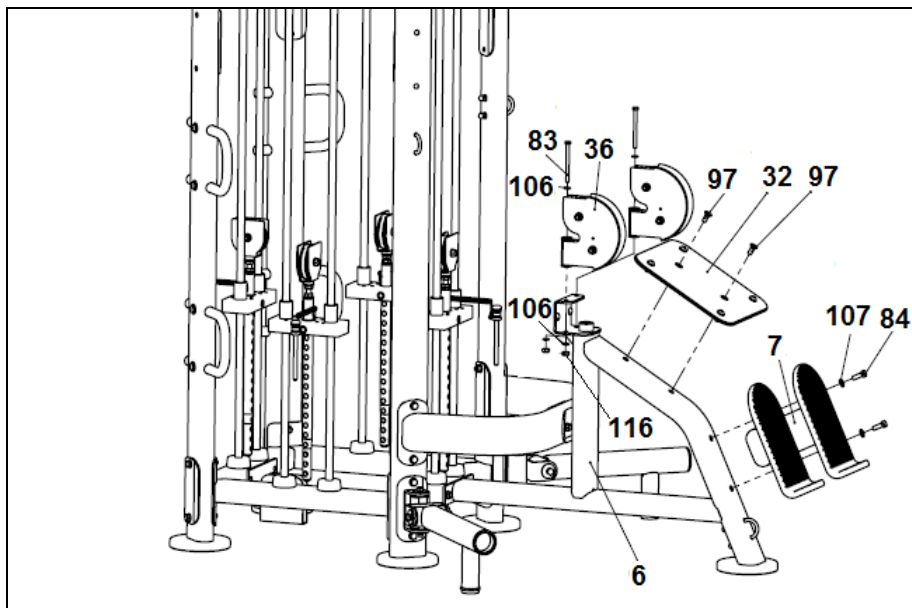

Coloque la placa metálica (32) sobre el soporte banco remo (6) y atornille con los tornillos (97) y apriete fuertemente. Coloque el soporte reposapiés (7) sobre el soporte banco remo (6) y atornille con los tornillos (84) y arandelas (107) y apriete fuertemente.

Coloque los soporte de polea (36) en el soporte del banco remo tal y como indica la figura 5 y fíjelos con los tornillos (83) junto con las arandelas (106) y las tuercas (116) y apriete fuertemente.



Place the fixed plate (32) on the rower support (6) and with the screws (97) tighten securely. Place the footrest bracket (7) on the rower support (6) and with the screws (84) and washers (107) tighten securely.

Place the double pulley brackets (36) in the rower support bracket as shown in Fig 5, and secure with screws (83) with washers (106) and nuts (116) and tighten securely.

Fig.6

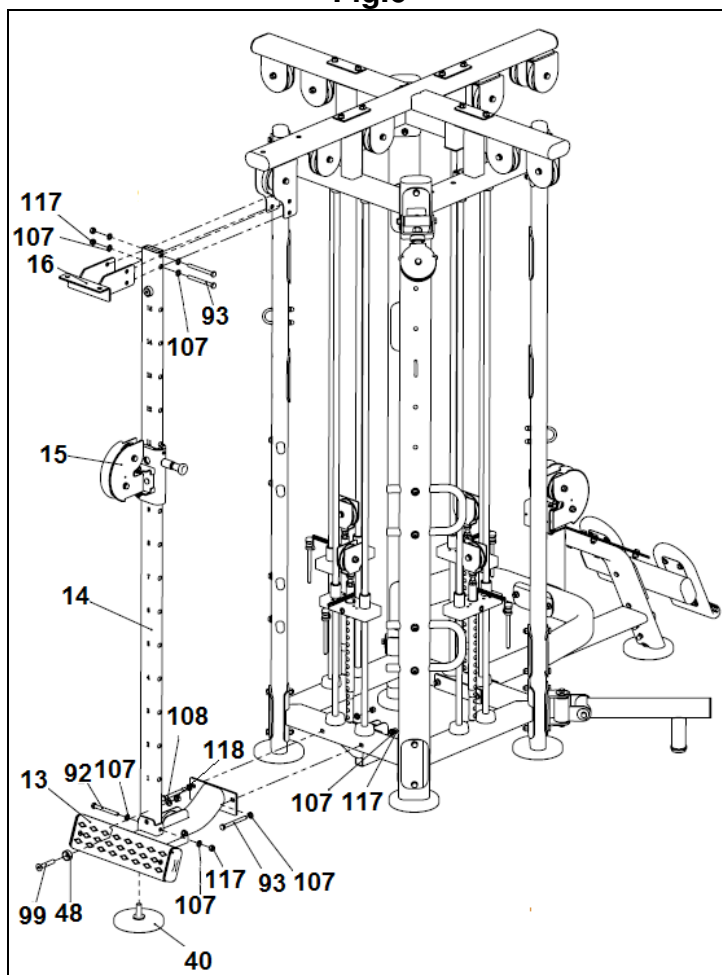

Coloque en el soporte (13) el taco de apoyo (40) y fíjelo con el tornillo junto con la arandela y la tuerca suministrado en el taco (40).

Introduzca en el mástil de posiciones (14) el selector de posiciones (15) tal y como muestra la fig. 6. Posicione el mástil de posiciones (14) en la "U" del soporte inferior (13), atorníllelo a las "U" con los tornillos (92) y (93) y el taco (118) y arandela (108) y con las arandelas (107) y las tuercas (117) como se indica en la figura 6.

Posicione el mástil de posiciones (14) junto con el soporte inferior en el bastidor principal (5). Atorníllelo en la parte superior junto con la pletina (16) al soporte (4) con los tornillos (93) junto con las arandelas (107) y las tuercas (117) y al bastidor principal (5) según la figura 6.



Place the adjusting pad (40) in the support (13) and screw with the screw, washer and nut included in the pad (40).

Insert in the adjusting tube (14) the selector frame (15) as shown in Fig. 6. Position the adjusting tube (14) in the "U" rear frame (13), screw the "U" with screws (92) and (93), nylon nut (118), washer (108), washers (107) and nuts (117) as shown in Figure 6. Place the adjusting tube (14) with the rear brake (13) on the main frame (5). Fit on the top along with the plate (16) to the upper support (4) with screws (93), washers (107) and nuts (117) and to the main frame (5) according to Fig 6.

Fig.7

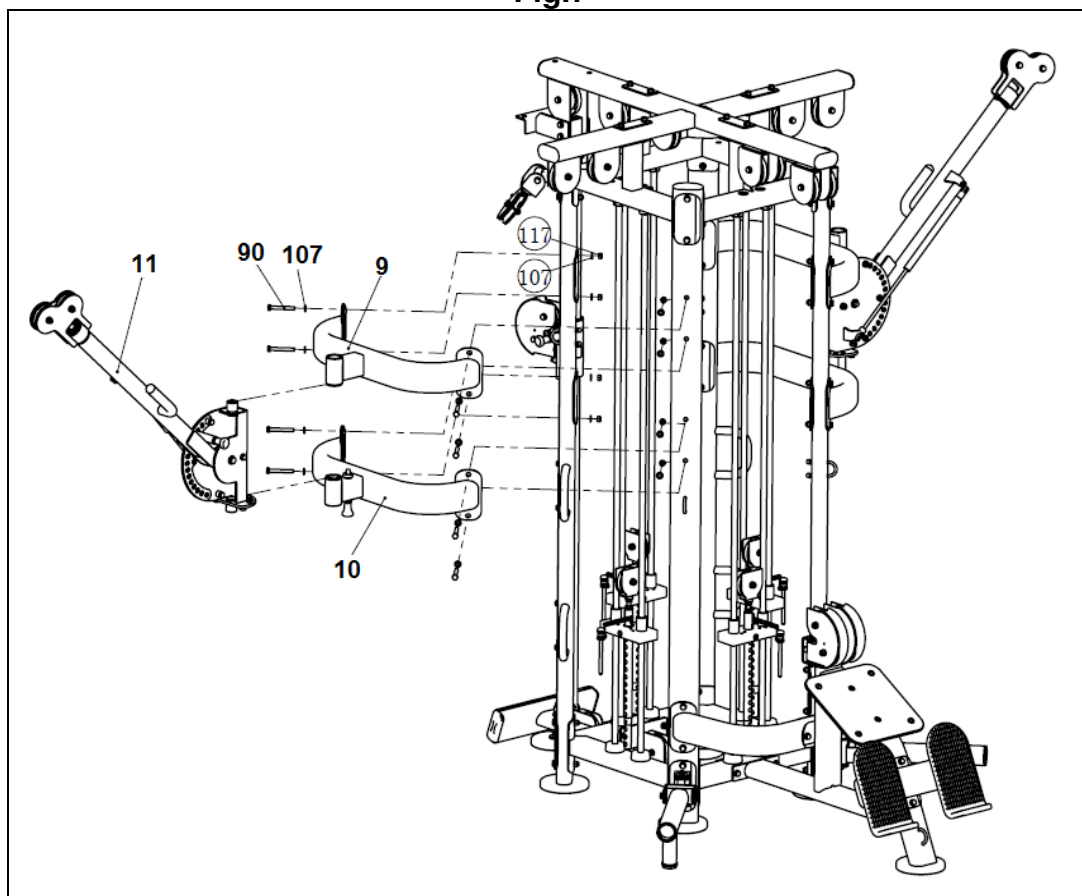

Coloque el soporte inferior del brazo Butterfly (10) en los brazos laterales (2L) y (1) como indica la figura 7. Atorníllelo con los tornillos (90) junto con las arandelas (107) y las tuercas (117). Una vez apretado coloque el eje del brazo Butterfly (11) en el soporte (10) e introduzca el eje superior del brazo Butterfly en el soporte (9). Fije el soporte (9) a los brazos laterales (2L) y (1) como indica la figura 7. Atorníllelo con los tornillos (90) junto con las arandelas (107) y las tuercas (117). Realice el mismo montaje descrito anteriormente con el brazo derecho (11R).



Place the lower support arm Butterfly (10) in the side arms (2L) and (1) as shown in Figure 7. Screw the screws (90) with washers (107) and nuts (117). A tight time place the Butterfly arm shaft (11) in the bracket (10) and enter the upper arm shaft Butterfly on the support (9). Attach the support (9) to the side arms (2L) and (1) as shown in Figure 7. Screw the screws (90) with washers (107) and nuts (117). Perform the same setup described above with the right arm (11R).

Fig.8

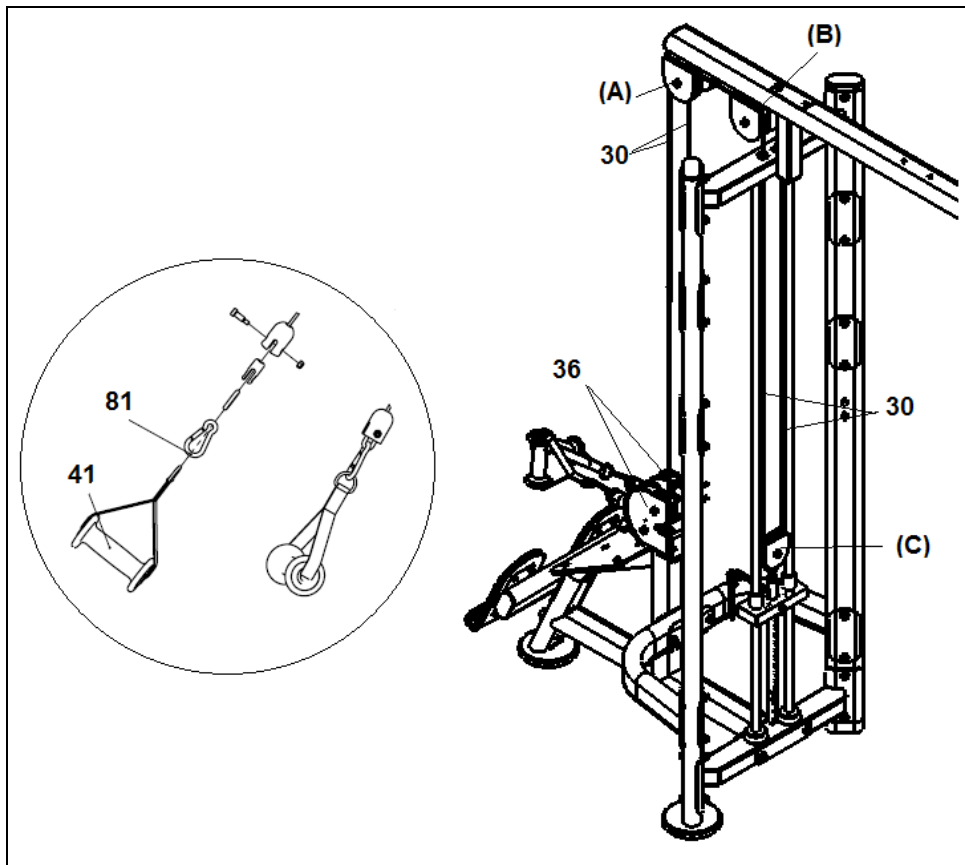

E

Coja el cable (30) y enb্রে el cable en las poleas (A) y (B) que se encuentra en el soporte poleas (3) y en la polea (C) hasta los soportes poleas (36) tal y como se muestra en la figura 8.

Coja los enganche de cadenas (81) y una los extremos del cable (30) con los tensores y únalos al asa (41) como muestra la figura 8.

GB

Take the cable and thread the cable on pulleys (A) and (B) located in the pulley bracket (3) and through the pulley (C) to the double pulley bracket (36) as shown in fig 8.

Take the chain hook (81) and join the end of cable (30), which you have just threaded through, with the cable tensioner and join to the handle (41). Fig.8.

Fig.9

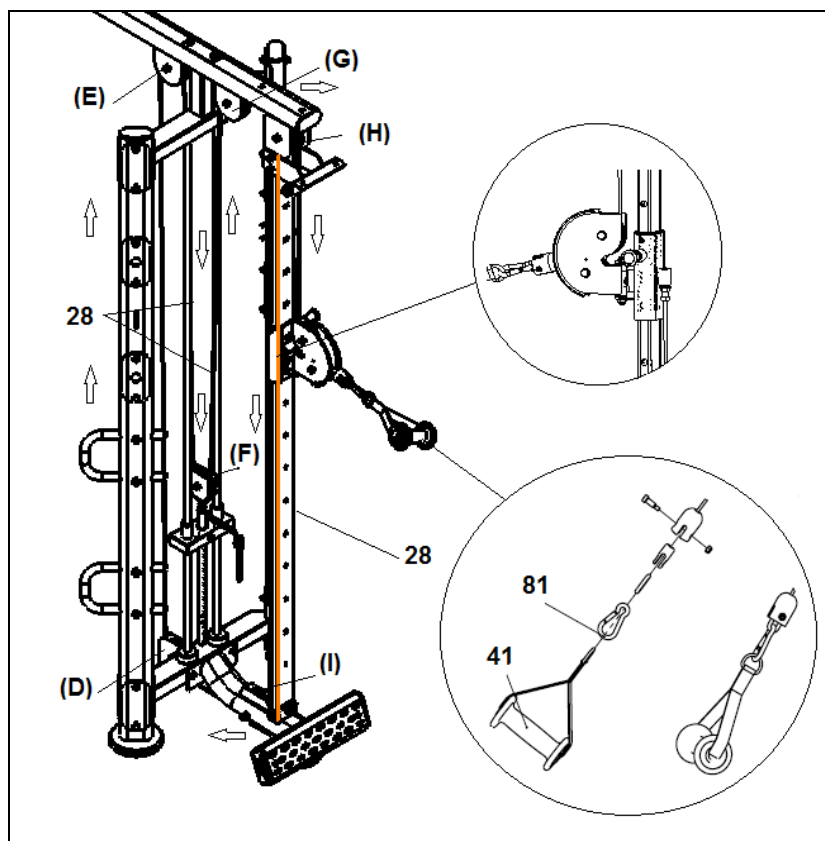

E

Sujete el extremo del cable (28) a la tuerca tensora de cables como se indica en la figura 9.
Coja el otro extremo del cable (28) y siguiendo las flechas indicadas en el cable páselos por las poleas indicadas como (D), (E), (F), (G), (H), (I).
Seguido pase la punta del cable (28) por la polea (J),
Coja el enganche de cadenas (81) y una el extremo del cable (28) con el tensor y únalo al asa (41) como muestra la figura 9.

GB

Attach the end of the cable (28) to the cable tensioning nut as shown in Figure 9. Take the other end of the cable (28) and looking the arrows shown thread it through the pulley marked as (D), (E), (F), (G), (H), (I). Then thread the end of the cable (28) through the pulley (28). Take the chain hook (81) and join the end of cable (28), which you have just threaded through, with the cable tensioner and join to the handle (41). Fig.9.

Fig.10

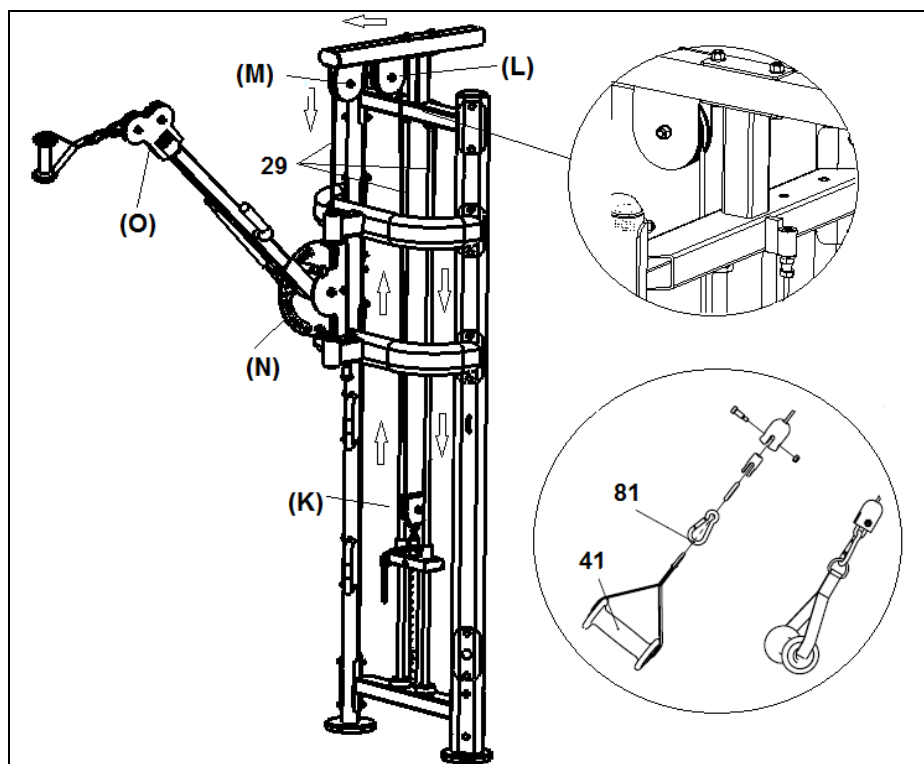

Sujete el extremo del cable (29) a la tuerca tensora de cables como se indica en la figura. Coja el otro extremo del cable (29) y enbreme el cable en las poleas (K), (L), (M), (N) y (O) como muestra la figura.

Coja el enganche de cadenas (81) y una el extremo del cable (29) con el tensor y únalo al asa (41) como muestra la figura 10.

Realice el mismo montaje para el cable del brazo Butterfly (11R), descrito anteriormente.



Attach the end of the cable (29) to the cable tensioning nut as shown in figure 10. Take the other end of the cable (29) and looking the arrows shown thread it through the pulley marked as (K), (L), (M), (N) and (O). Take the chain hook (81) and join the end of cable (29), which you have just threaded through, with the cable tensioner and join to the handle (41). Fig.10.

Perform the same setup described above with the Butterfly arm cable (11R).

Fig.11

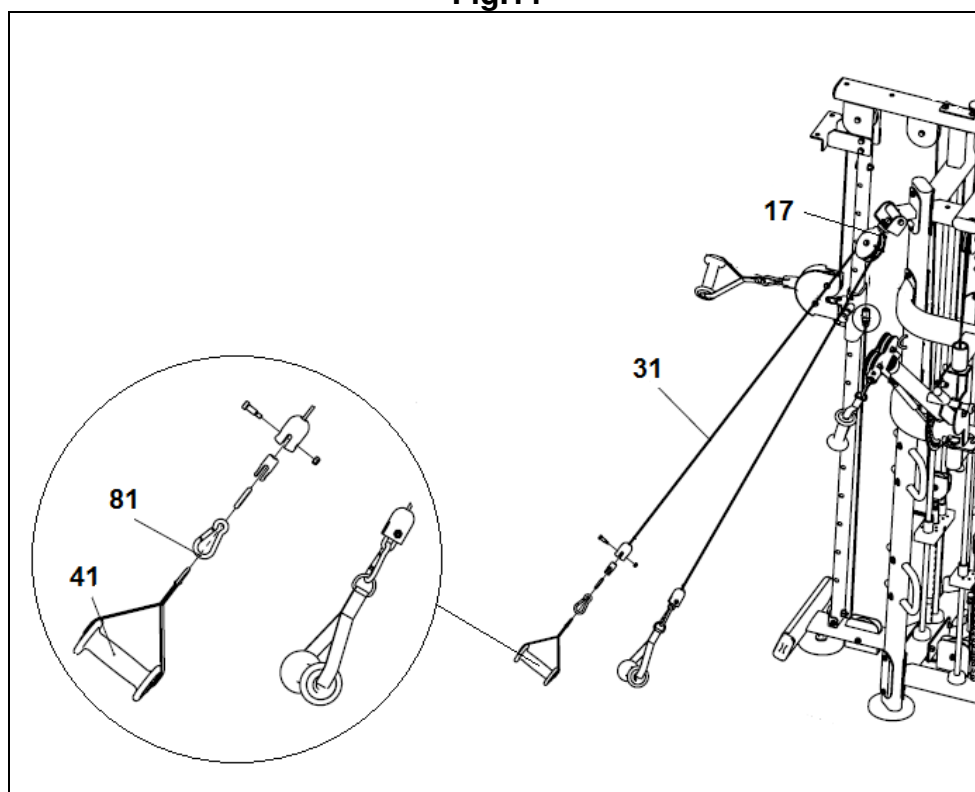

Por último enbrea el cable (31) en la polea (17) tal y como se muestra en la figura 11.
Coja los enganche de cadenas (81) y una los extremos del cable (31) con los tensores y únalos al asa (41) como muestra la figura 11.



Finally thread the cable (31) on pulleys (17) and (B) as shown in fig 11.
Take the chain hook (81) and join the end of cable (31), which you have just threaded through, with the cable tensioner and join to the handle (41). Fig.11.

MUY IMPORTANTE:

Una vez realizado el montaje, compruebe que todos los tornillos que han sido montados en esta maquina, están fuertemente apretados.

VERY IMPORTANT:

After assembling the unit, check that all of the screws have been fitted to the machine and that they are tightened securely.

L360FS

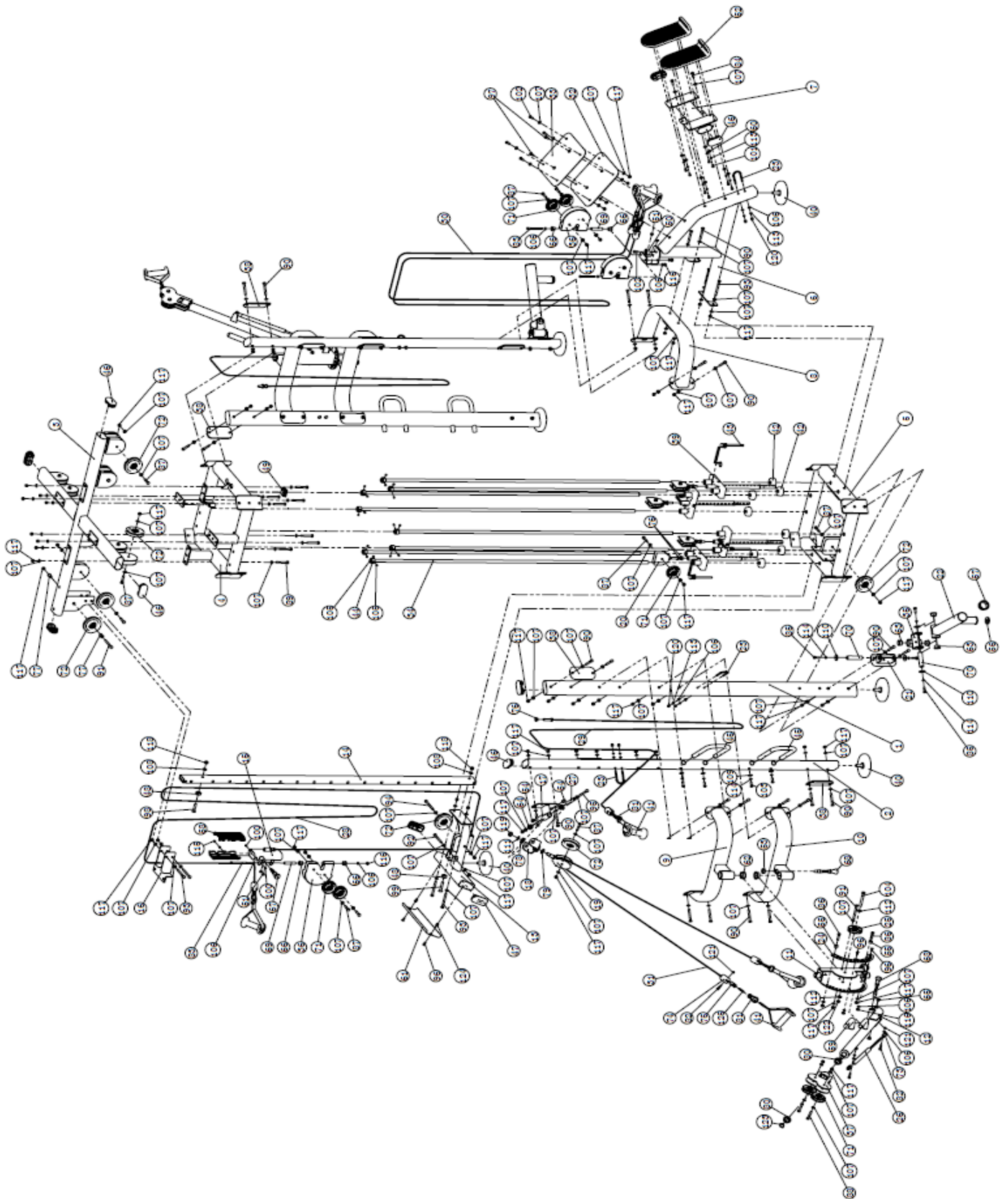

Para pedido de repuesto: Indicar el código de la pieza y la cantidad.
To order replacement parts: State the part code and Quantity.

Nº	Code	Nº	Code	Nº	Code	Nº	Code
1	A-L360FSK0100	33	A-L360FSK3500	65	A-BNH0528	97	A-CNLM10*25DS20
2	A-L360FSK0200	34	A-L360FSK3600	66	A-L1-6800	98	A-CNLM12*60DS20
3	A-L360FSK0300	35	A-IZ70120200	67	A-IZ70051000	99	A-CNLM12*70DS20
4	A-L360FSK0400	36	A-IT9325G1500	68	A-IT9315G1500	100	A-PNLM6*12DS20
5	A-L360FSK0500	37	A-HG51200	69	A-IN-D20021000	101	A-PNLM8*15DS20
6	A-L360FSK0600	38	A-AXT3S0302	70	A-IZ70120400	102	A-PNLM10*25DS20
7	A-L360FSK0700	39	A-IT93021900	71	A-M01004800	103	A-PNLM10*40DS20
8	A-L360FSK0800	40	A-IT93201800	72	A-SG500110400	104	A-YLS0.5*13*95DS20
9	A-L360FSK0900	41	A-CWRVL0021600	73	A-MFT-7002700	105	A-GB77M8*8DS18
10	A-L360FSK1000	42	A-IT80023000	74	A-IT90302303	106	A-GB958DS2
11	A-L360FSK1100	43	A-IE95191400	75	A-IN-D20020802	107	A-GB9510DS2
12	A-L360FSK1200	44	A-IT93252800	76	A-HF900-03A1002	108	A-GB9512DS2
13	A-L360FSK1300	45	A-IZ70010600	77	A-KFFT0700	109	A-DQ10DS2B
14	A-L360FSK1400	46	A-IT90013800	78	A-GB30151104	110	A-DQ10DS2D
15	A-L360FSK1500	47	A-IT80101800	79	A-GB27661804-2Z	111	A-DQ16DS2
16	A-L360FSK1600	48	A-CMJ61752100	80	A-GB2766005-2Z	112	A-YDQ13.5*27*2DS2
17	A-L360FSK1700	49	A-KPSFID3000	81	A-HLG8DS2	113	A-GB938DS12
18	A-L360FSK1800	50	A-BNH0514	82	A-BNH0718	114	A-GB9310DS12
19	A-L360FSK1900	51	A-BNH0533	83	A-GB5780M8*100DS20	115	A-GB41M6
20	A-L360FSK2000	52	A-IT80261500V1	84	A-GB5780M10*30DS2NL	116	A-NM8DS2
21	A-L360FSK2100	53	A-TCS130WS4700	85	A-GB5780M10*30DS20	117	A-NM10DS2
22	A-L360FSK2200	54	A-SL70013200	86	A-GB5780M10*40DS20	118	A-NM12DS2
23	A-L360FSK2500	55	A-FS544600	87	A-GB5780M10*50DS20	119	A-NM16DS2
24	A-L360FSK2600	56	A-TPF-533000	88	A-GB5780M10*55DS20	120	A-GB923M8DS2
25	A-L360FSK2700	57	A-HV66700	89	A-GB5780M10*75DS20	121	A-YNM0.313*18*8DS2

26	A-L360FSK2800	58	A-IN-B72011700	90	A- GB5780M10*80DS20	122	A-YNM0.5*13*8DS2
27	A-L360FSK2900	59	A-KL22019500	91	A- GB5780M10*95DS20	123	A-GB894.125DS12
28	A-L360FSK3000	60	A-TBT12100	92	A- GB5780M10*100DS20	124	A- GB17880.5M8*16.5DCS17
29	A-L360FSK3100	61	A-IT9008B3800	93	A- GB5780M10*105DS20	125	A-LHφ6.8*1DS2
30	A-L360FSK3200	62	A-HVCORE5400	94	A- GB5780M10*115DS20	130	A-IT80033200ST
31	A-L360FSK3300	63	A-M02502000	95	A- GB5780M10*120DS20	131	A-IT80033300ST
32	A-L360FSK3400	64	A-HF985A1800	96	A-CNLM8*20DS20	132	A-IT80124400ST

BH HIPOWER SPAIN

EXERCYCLE,S.L. (Manufacturer)
P.O.BOX 195
01080 VITORIA (SPAIN)
Tel.: +34 945 29 02 58
Fax: +34 945 29 00 49
e-mail: hipower@bhfitness.com
www.bhfitness.com

POST-VENTA

Tel: +34 945 292 012 /
902 170 258
Fax: +34 945 56 05 27
e-mail: hipower@bhfitness.com

BH HIPOWER PORTUGAL

MAQUINASPORT, APARELHOS
DE DESPORTO, S.A.
Rua do Caminho Branco Lote
8, ZI Oiã 3770-068 Oiã
Oliveira do Bairro (PORTUGAL)
Tel.: +351 234 729 510
Fax: +351 234 729 519
e-mail: info@bhfitness.pt

BH SERVICE PORTUGAL

Tel.: +351 234 729 510
Fax: +351 234 729 519
e-mail: info@bhfitness.pt

BH HIPOWER UK

Tel: 02037347554
e-mail:
sales.uk@bhfitness.com

AFTER SALES – UK

Tel.: 02074425525
e-mail:
service.uk@bhfitness.com

BH HIPOWER NORTH AMERICA

20155 Ellipse
Foothill Ranch
CA 92610
Tel: + 1 949 206 0330
Toll free: +1 866 325 2339
Fax: +1 949 206 0013
e-mail:
fitness@bhnorthamerica.com
www.bhnorthamerica.com

BH HIPOWER MEXICO

BH Exercycle de México S.A.
de CV
Eje 132 / 136
Zona Industrial, 2A Secc.
78395 San Luis Potosí
S:L:P: MÉXICO
Tel.: +52 (444) 824 00 29
Fax: +52 (444) 824 00 31
www.bh.com.mx

BH HIPOWER FRANCE**SAV FRANCE**

Tel : +33 0810 000 301
Fax : +33 0810 000 290
savfrance@bhfitness.com

BH HIPOWER ASIA

No.139, Jhongshan Rd.
Daya Township
Taichung 428, Taiwan. R.O.C.
Tel.: +886 4 25609200
Fax: +886 4 25609280
e-mail: info@bhasia.com.tw

BH HIPOWER CHINA

BH China Co., Ltd.
Block A, NO.68, Branch Lane
455, Lane 822,
Zhen Nan RD., Li Zi Yuan,
Putuo, Shanghai 200331,
P.R.C.
Tel: +86-021-5284 6694
Fax:+86-021-5284 6814
e-mail: info@i-bh.cn

BH Germany GmbH

Altendorfer Str. 526
45355 Essen
Tel: +49 201 450910-0
e-mail: info@bhgermany.com
Kostenfreie Telefonnummer:
0800 0996655
Ersatzteile:
www.bhfitness.com

BH SE RESERVA EL DERECHO A MODIFICAR LAS ESPECIFICACIONES DE SUS PRODUCTOS SIN PREVIO AVISO.

SPECIFICATIONS MAY BE CHANGED WITHOUT PRIOR NOTICE DUE TO OUR PROGRAMME OF CONTINUOUS PRODUCT DEVELOPMENT.

BH SE RÉSERVE LE DROIT DE MODIFIER LES SPECIFICATIONS DE SES PRODUITS SANS PRÉAVIS.

BH BEHALT SICH DAS RECHT VOR, ÄNDERUNGEN DER MODELL-ANGABEN OHRE VORHERIGE ANKÜNDIGUNG VORZUNEHMEN.

DATI TECNICI E COMMERCIALI RELATIVI AGLI ARTICOLI DEL PRESENTE CATALOGO POSSONO ESSERE SOGGETTI A VARIAZIONI SENZA ALGUN PREAVVISO.

BH SE RESERVA O DIREITO A MODIFICAÇÃO ESPECIFICAÇÕES DOS SEUS PRODUCTOS SEM PRÉVIO AVISO.

DOOR KONSTANTE PRODUKTVERNIEUWING EN VERBETERING HOUDEN WIJ ONS HET RECHT VAN WIJZIGING VOOR ZONDER VOORAFGAAND BERICHT.